

AFTERCARE INSTRUCTIONS

Your fitting has a high quality finish and should be treated with care to preserve the visible surfaces.

All surface finishes will wear if not cleaned correctly, the only safe way to clean your mixer is to wipe with a soft damp cloth. Stains can be removed using washing up liquid. All bath cleaning powders and liquids will damage the surface of your fitting, even the non-scratch cleaners. **NOTE: Never use abrasive detergents or disinfectants or those containing alcohol, hydrochloric acid or phosphoric acid.**

Bristan recommend E-Cloth for cleaning all of our bathroom & kitchen products. Using just water, E-cloth gives a smear free, deep clean by breaking up and holding dirt, which normal cloths leave behind. Order through your Bristan stockist. (ORDER CODE: ECLOTH)



GUARANTEE

All products are manufactured to the highest standards and a 5 year guarantee covers any defect in manufacture.

NOTE: The 5-year guarantee on the cartridge is invalidated if damaged by any waterborne debris.

All products must have access for servicing or replacement during the life of the product.

In the interests of continuous product development we reserve the right to alter specification as necessary

PRODUCT CODE: AR SHXVOFF C, AR SHXSMFF C, AR SHXMTFF C

PRODUCT IDENTIFICATION CODE LASER ETCHED ON PRODUCT
Installer please fill in code here _____.(Where applicable)

TELEPHONE HELPLINE: 0844 701 6273

Bristan Group Limited
Birch Coppice Business Park
Dordon
Tamworth
Staffordshire
B78 1SG
UK
A Masco Company
Website: www.bristan.com
Telephone: 0844 701 6274
Facsimile: 0844 701 6275

BRISTAN

Artisan Thermostatic Surface Mounted Bar Shower Valve with Fast Fit Connections

Fitting Instructions & Contents List

Before starting any installation project please consider:

Prior to drilling into walls, check there are no hidden electrical wires, cables or water supply pipes with the aid of an electronic detector. If you use power tools do not forget:



- Wear eye protection
- Unplug equipment after use

Please keep these instructions for future reference and request of replacement part.

CONTENTS

Section	Description	Page
1.	Introduction	2
2.	Specification	2
3.	Pack contents checklist	2
4.	Installation	3
5.	Operation	8
6.	Setting	8
7.	General fault diagnosis	8
8.	Cleaning & Maintenance	9
9.	Fault Diagnosis Table	10

9. FAULT DIAGNOSIS TABLE

FAULT DIAGNOSIS	
Symptoms	Cause / Rectification
Only hot or cold water from mixer outlet.	Inlets reversed (hot supply to cold supply). Check that the hot & cold connections are the correct way round. Hot on the left, cold on the right when viewed from the front. Rework pipework as necessary.
Outlet temperature too hot / too cold.	No hot or cold water reaching the mixer.
	Check the insert filters for any blockage.
	Installation conditions outside operating parameters, refer to " Specification " section.
Fluctuating or reduced flow	Check the shower handset, hose and filters for any blockage.
	Make sure that the maintained inlet pressures are nominally balanced and sufficient, refer to the " Specifications " section.
	Make sure that the inlet temperature differentials are sufficient, refer to " Specification " section.
	Air lock or partial blockage in the pipework.
Water leaking from shower head.	This is normal for a short period after shut off.
	Check that the pressures do not exceed the specification for the product, refer to " Specification " section.
	Cartridge inlet seals damaged, renew.
	Replace the flow cartridge.

8. CLEANING & MAINTENANCE

8.1 Cleaning

Your fitting has a high quality finish and should be treated with care to preserve the visible surfaces.

All surface finishes will wear if not cleaned correctly, the only safe way to clean your mixer is to wipe with a soft damp cloth. Stains can be removed using washing up liquid. All bath cleaning powders and liquids will damage the surface of your fitting, even the non-scratch cleaners.

8.2 Regular Maintenance

We advise that the valve is regularly serviced, particularly in hard water areas. It is also important to clean the handset regularly in hard water areas to maintain an even spray/flow of water.

NOTE: ISOLATE THE WATER SUPPLY TO THE SHOWER VALVE.

8.3 Cartridge Removal (See Fig. 1b)

8.3.1 Remove the temperature control handle (15), by removing the head cap (17) and unscrew the head screw (16).

8.3.2 Unscrew the cartridge (13) anticlockwise out of the body.

8.4 Cartridge Maintenance

8.4.1 Place the cartridge in a bowl and carefully add some hot water (just off the boil) and vinegar to de-scale the cartridge. Leave until the water has cooled.

8.4.2 Then remove the cartridge and rinse with clean water.

8.5 Refitting the Cartridge

8.5.1 Grease the seals with suitable silicon grease and carefully refit the cartridge into the body.

8.5.2 Reset the maximum temperature and refit temperature handle.

1. INTRODUCTION

Your Bristan dual control shower fitting is a thermostatic mixer incorporating a wax capsule thermostat to ensure constant showering temperatures.

This valve has been designed to comply with BS EN 1287: 1999 & EN 1111 1999. Manufactured to the highest quality standards.

These instructions are for your guidance to a safe and successful installation and should be left with the user.

All products manufactured and supplied by Bristan are safe provided they are installed, used correctly and receive regular maintenance in accordance with these instructions.

2. SPECIFICATION

Inlet Connections: 15mm compression with 150mm between centres.
Water Pressures: Min. 0.1 bar (AR SHXSMFF C & AR SHXMTFF C) Max. 5 bar, 0.2 (AR SHXVOFF C) Max. 5 bar
Maximum recommended imbalance between hot and cold supply should not exceed a ratio of 5:1
Maximum Outlet Temp: Factory Set to 38°C to the Temperature stop (can be re-set to suit conditions).

Hot & Cold Supply Temperature

Maximum Cold Supply: 25°C

Recommended hot supply: 60°C to 65°C

(NOTE! - The mixing valve can operate at temperatures up to 80°C, however for safety reasons, it is recommended that the maximum hot water temperature is limited to 60°C)

Note: the inlet hot water temperature must be at least 10°C above the required blend temperature.

3. PACK CONTENTS CHECK LIST

1 x Shower Valve
4 x Screws
4 x Wall Plugs
2 x Wall Plates
2 x 15mm Olives
2 x Fixing Bridge
2 x Shroud
2 x Filter Washer
1 x Shower Kit and Fixings (AR SHXSMFF C & AR SHXMTFF C)

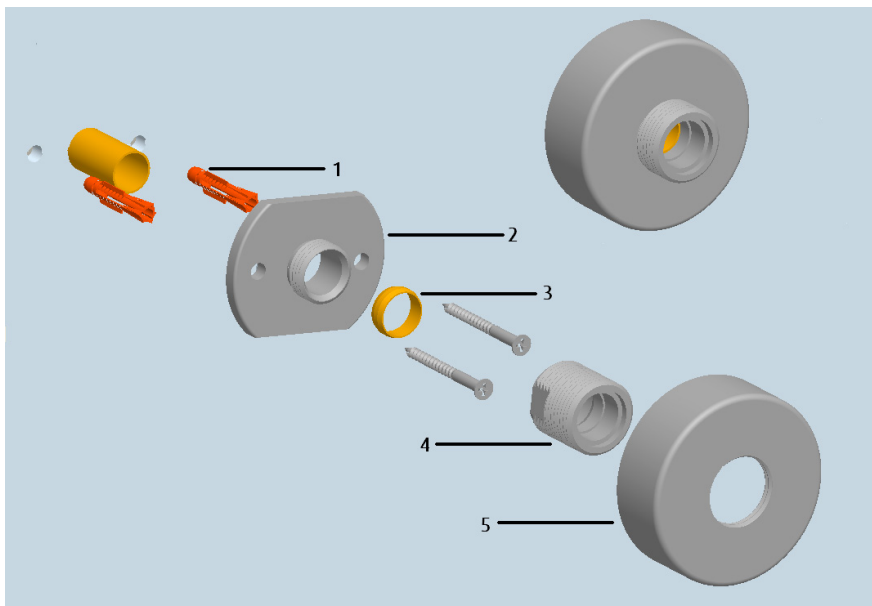

4. INSTALLATION

4.1 Pre-Installation (See Fig. 1a & 1b)

4.1.1 Identify all components and check for completeness, particularly before arranging fitting.

4.1.2 This mixer should be installed in compliance with Water Regulations. For further details contact your Local Water Authority.

4.1.3 This mixing valve is suitable for use with the following systems:

- Gravity Fed Hot & Cold (Equal Pressure)
- Gravity Fed Hot & Mains Cold (Different Pressure Maximum Ratio 5:1)
- Un-vented Systems
- Thermal Store Systems
- Gas Combination Boiler
- Pumped System

PLEASE NOTE:

On gravity systems the minimum distance from the underside of the cold-water storage tank to the shower head must be at least 1 metre.

4.1.4 Before fitting the fast fit wall fixings, water should be flushed through the system to remove all debris from the pipe work.

5. OPERATION

5.1 On/off - Flow Control

There are two control handles on the shower. Turn the flow control handle (left) anti-clockwise to turn on and increase the flow, and clockwise to decrease and turn off. There is a stop point at the half way point, this is a water saving device to override this press in the button and turn the handle past the stop point. When turning off the shower handle will click when it passes the stop position this is quite normal. The temperature control handle (right) is turned anti-clockwise for hot, clockwise for cold.

6.1 The maximum temperature can be adjusted to suit site conditions or user preference. To adjust this, follow this procedure:

6.2 Position the temperature control handle to the maximum temperature point and turn on the flow handle control handle letting the water run long enough to ensure that the hot water supply is at its maximum temperature.

6.3 The shower has been factory set at 38°C at the first stop position with balanced supply pressures of 0.5 bar.

6.4 **Whilst the water is flowing** remove the temperature control handle (15), by removing the head cap (17) and unscrew the head screw (16).

6.5 Turn the cartridge spindle (a) until the required maximum temperature is achieved (the spindle may need to be repositioned to allow the head to line back up with the stop ring (14) on the shower), anti-clockwise to increase the temperature and clockwise to reduce it.

6.6 **Important:** Refit the handle so that the stop pin in the handle (15), fits inside the rim of the nylon stop ring (14).

6.7 Push the handle back on and turn clockwise.

6.8 Turn off the flow at the flow control handle.

7. GENERAL FAULT DIAGNOSIS

7.1 If your valve fails to function correctly, the following should be checked:

7.1.1 Check that the hot and cold connections are the correct way around. Hot on the left, cold on the right when viewed from the front.

7.1.2 Ensure that the hot water temperature is adequate. The recommended minimum temperature is 60°C.

7.2 If your shower will not turn off.

7.2.1 Check ceramic disc valve (12) is free of debris.

7.3 If your shower has a low flow rate.

7.3.1 Check that the filters (6) are not blocked.

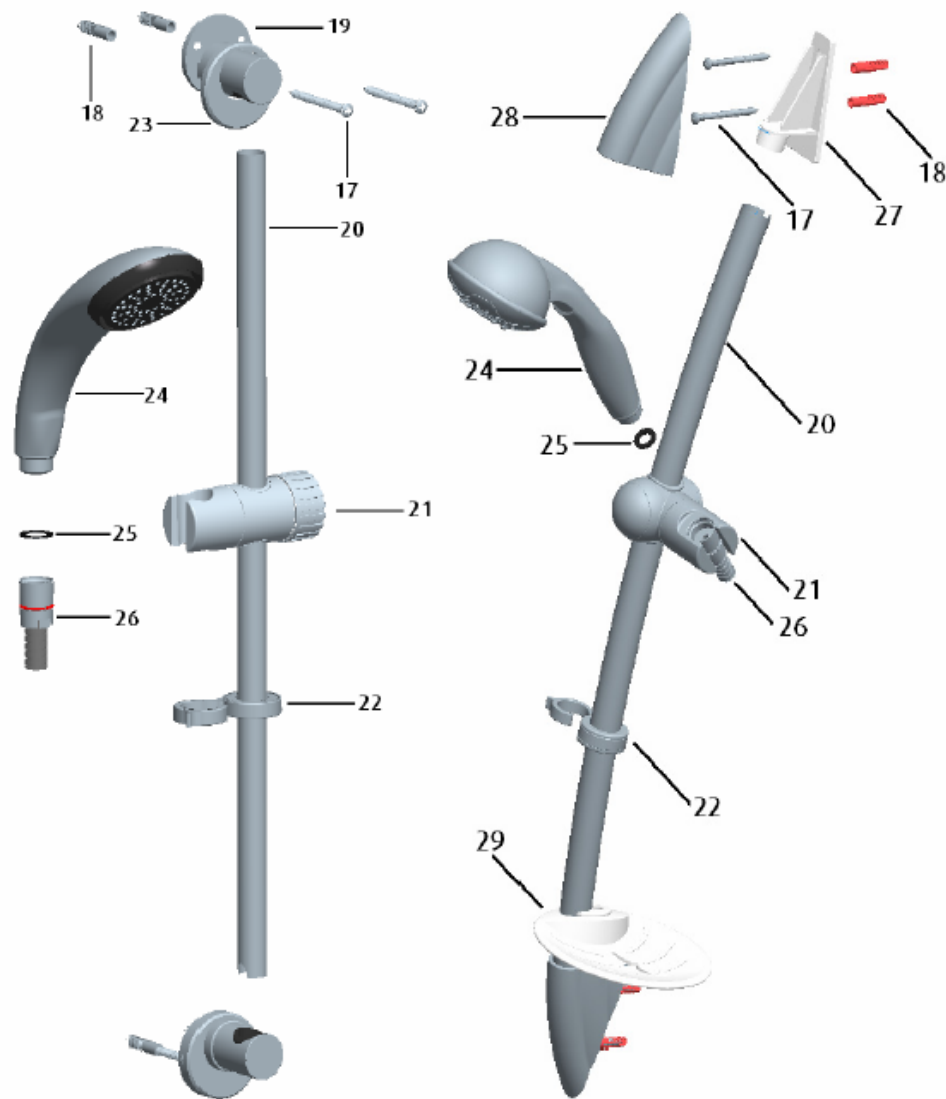

Fig. 2a

Fig. 2b

4.2 INSTALLATION

Prior to drilling into walls, check there are no hidden electrical wires, cables or water supply pipes with the aid of an electronic detector. If you use power tools do not forget:



- Wear eye protection
- Unplug equipment after use

4.2.1 Fast Fit Fixing Kit (See Fig. 1a)

4.2.1.1 Identify all components and check for completeness, particularly before arranging fitting.

NOTE:- The fixing centres are a **NOMINAL DISTANCE** of 150mm, therefore **before drilling holes for the supply pipes check the centre dimension of the actual product to be used.**

4.2.1.2 Inlet pipes need to terminate with at least 30mm of 15mm diameter pipe (not supplied) protruding through the finished wall surface.

Important:- Water supplies to the mixer must be with the **Hot on the left & Cold on the right** when viewed from the front.

4.2.1.3 Place the wall plate (2) over the pipe and mark the hole centres, drill two holes to suit the wall plugs (1) and insert the wall plugs into the freshly drilled holes in the wall.

4.2.1.4 Place the wall plate (2) with onto the wall and tighten up the screws until secure. Place the olive (3) onto the protruding 15mm pipe. The pipe needs to protrude past the olive by 5mm maximum.

4.2.1.5 Screw the fixing bridge (4) onto the wall plate (2) using a 22mm a/f spanner, holding the wall plate (2) with the flats provided with a 47mm spanner - **DO NOT** tighten up the fixing bridge (4) against the fixings (1).

4.2.1.6 Screw shroud (5) onto fixing bridge (4).

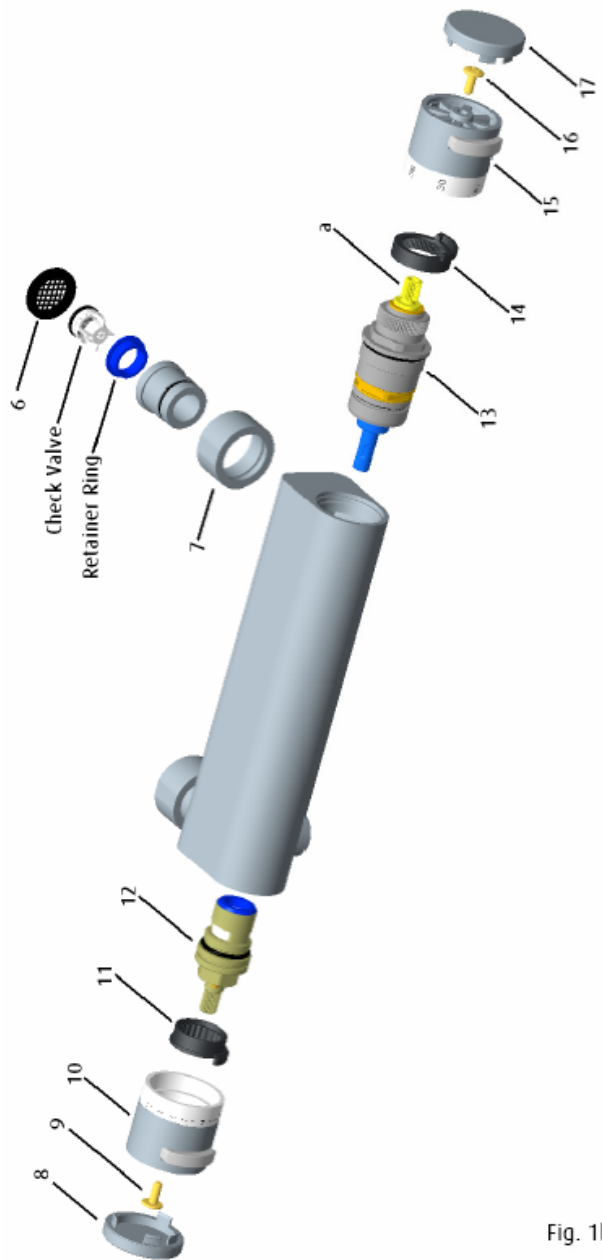

Fig. 1b

4.2.2. Bar Shower Body (See Fig. 1b)

To fit mixer body to the wall. Place the filter washers (6) into the connecting nuts (7) and tighten to the fixing bridge (4 on page 3. Fig. 1a) using the connecting nuts (7) which are secured to the mixer body.

4.3 Single Function Adjustable Riser Installation (See Fig. 2a, page 7)

Prior to drilling into walls, check there are no hidden electrical wires, cables or water supply pipes with the aid of an electronic detector. If you use power tools do not forget:



- Wear eye protection
- Unplug equipment after use

4.3.1 Use the riser tube (20) assembled with the wall brackets (19) as a template to mark out the position of the required mounting holes. Before drilling ensure that the handset will reach the slider when it is in the extreme position. Drill holes to suit wall plugs (18) if required.

4.3.2 Slide the handset holder (21), the hose retaining ring (22) and the 2 wall bracket covers (23) (one at each end) onto the tube (20). Re-fit the wall brackets and secure to wall using screws supplied (17). Slide the wall bracket covers (23) over the wall brackets and clip into place. Connect the hose (26) to the handset (24) connected, using the small sealing washers (25).

4.3.3 Feed one end of the shower hose through the hose retainer (22) and connect the hose to either the wall outlet or directly to the shower valve using the second small sealing washer (25).

4.4 Multi Function Adjustable Riser Installation (See Fig. 2b, page 7)

4.4.1 Use the riser tube (20) assembled with the wall brackets (27) as a template to mark out the position of the required mounting holes. Before drilling ensure that the handset will reach the slider when it is in the extreme position. Drill holes to suit wall plugs (18).

4.4.2 Slide the handset holder (21), the soap dish (29) the hose retaining ring (22) and 2 wall bracket covers (28) (one at each end) onto the tube (20). Re-fit the wall brackets and secure to wall using supplied screws (17). Slide the wall brackets covers (28) over the wall brackets and clip into place. Connect the hose (26) to the handset (24) connected, using the small sealing washers (25).

4.4.3 Feed one end of the shower hose through the hose retainer (22) and connect the hose to the shower valve using the second small sealing washer (25).