



## TECHNICAL DETAILS

Model Reference - Natural Gas	EC230/600	EC230/700	EC230/960	EC380/740	EC380/980	EC380/1220	EC380/1400
Model Reference - Propane	LEC230/600	LEC230/700	LEC230/960	LEC380/740	LEC380/980	LEC380/1220	LEC380/1400
<b>Natural Gas, category I<sub>2H</sub></b>							
Gas consumption G20	3.41m <sup>3</sup> /h	4.09m <sup>3</sup> /h	5.43m <sup>3</sup> /h	4.09m <sup>3</sup> /h	5.43m <sup>3</sup> /h	6.82m <sup>3</sup> /h	7.92m <sup>3</sup> /h
Heat input gross (HS)	36.6 kW	43.9 kW	58.3 kW	43.9 kW	58.3 kW	73.2 kW	85.0 kW
Heat output	35.1 kW	41.3 kW	54.2 kW	43.0 kW	57.1 kW	71.0 kW	79.1 kW
Supply pressure	20 mbar	20 mbar	20 mbar	20 mbar	20 mbar	20 mbar	20 mbar
Gross thermal efficiency (NG)	96%	94%	93%	98%	98%	97%	93%
<b>Propane, category I<sub>3P</sub></b>							
Gas consumption G31	1.39m <sup>3</sup> /h	1.67m <sup>3</sup> /h	2.22m <sup>3</sup> /h	1.67m <sup>3</sup> /h	2.22m <sup>3</sup> /h	2.78m <sup>3</sup> /h	3.12m <sup>3</sup> /h
Heat input gross (HS)	36.6 kW	43.9 kW	58.3 kW	43.9 kW	58.3 kW	73.2 kW	85.0 kW
Heat output	35.1 kW	41.3 kW	54.2 kW	43.0 kW	57.1 kW	71.0 kW	79.1 kW
Supply pressure	37 mbar	37 mbar	37 mbar	37 mbar	37 mbar	37 mbar	37 mbar
Gross thermal efficiency (Propane)	96%	94%	93%	98%	98%	97%	96%
NOx level	25ppm	25ppm	25ppm	25ppm	25ppm	25ppm	25ppm
NOx level	44mg/kWh	44mg/kWh	44mg/kWh	44mg/kWh	44mg/kWh	44mg/kWh	44mg/kWh
Noise level (a)	51dBA	51dBA	51dBA	51dBA	51dBA	51dBA	51dBA
Recovery rate thru' 50°C	600 ltrs/hour	700 ltrs/hour	960 ltrs/hour	740 ltrs/hour	980 ltrs/hour	1220 ltrs/hour	1400 ltrs/hour
Storage recovery time @50°C rise	23mins	20mins	14mins	31mins	23mins	19mins	16mins
Concentric flue size (b)	100/150mm	100/150mm	100/150mm	100/150mm	100/150mm	100/150mm	100/150mm
Maximum flue run (concentric)	16 metres	16 metres	16 metres	16 metres	16 metres	16 metres	16 metres
Cold Inlet water connection	1½" BSP	1½" BSP	1½" BSP	1½" BSP	1½" BSP	1½" BSP	1½" BSP
Hot outlet water connection	1½" BSP	1½" BSP	1½" BSP	1½" BSP	1½" BSP	1½" BSP	1½" BSP
Drain port connection	¾" BSP	¾" BSP	¾" BSP	¾" BSP	¾" BSP	¾" BSP	¾" BSP
Secondary return connection	¾" BSP	¾" BSP	¾" BSP	¾" BSP	¾" BSP	¾" BSP	¾" BSP
Operating pressure (unvented)	3.5 bar	3.5 bar	3.5 bar	3.5 bar	3.5 bar	3.5 bar	3.5 bar
Maximum working pressure (vented)	10.3 bar	10.3 bar	10.3 bar	10.3 bar	10.3 bar	10.3 bar	10.3 bar
Maximum test pressure	20.7 bar	20.7 bar	20.7 bar	20.7 bar	20.7 bar	20.7 bar	20.7 bar
Gas connection (gas cock supplied)	¾" BSP	¾" BSP	¾" BSP	¾" BSP	¾" BSP	¾" BSP	¾" BSP
Electrical supply	230v/50Hz	230v/50Hz	230v/50Hz	230v/50Hz	230v/50Hz	230v/50Hz	230v/50Hz
Power consumption	120W	120W	210W	120W	210W	210W	210W
Fuse	5 amp	5 amp	5 amp	5 amp	5 amp	5 amp	5 amp
Weight empty	225kg	225kg	225kg	385kg	385kg	385kg	385kg
Weight full	450kg	450kg	450kg	760kg	760kg	760kg	760kg
Shipping weight	242kg	242kg	242kg	408kg	408kg	408kg	408kg
Shipping dimension - depth	889mm	889mm	889mm	889mm	889mm	889mm	889mm
Shipping dimension - width	819mm	819mm	819mm	819mm	819mm	819mm	819mm
Shipping dimension - height	1664mm	1664mm	1664mm	2197mm	2197mm	2197mm	2197mm

(a) Noise level measured at 2m from flue terminal.

(b) Reduce flue length by 1.2m for 90° bend, 0.7m for 45° bend and 1.5m for condense trap.

# PRODUCT DIMENSIONS

## ECoflo Models EC230/600, EC230/700, EC230/960

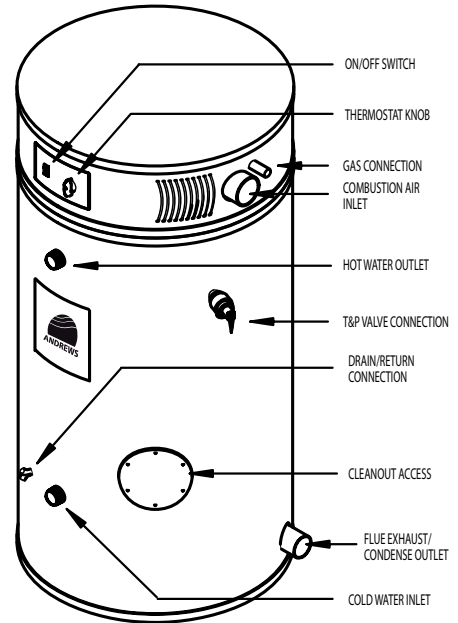
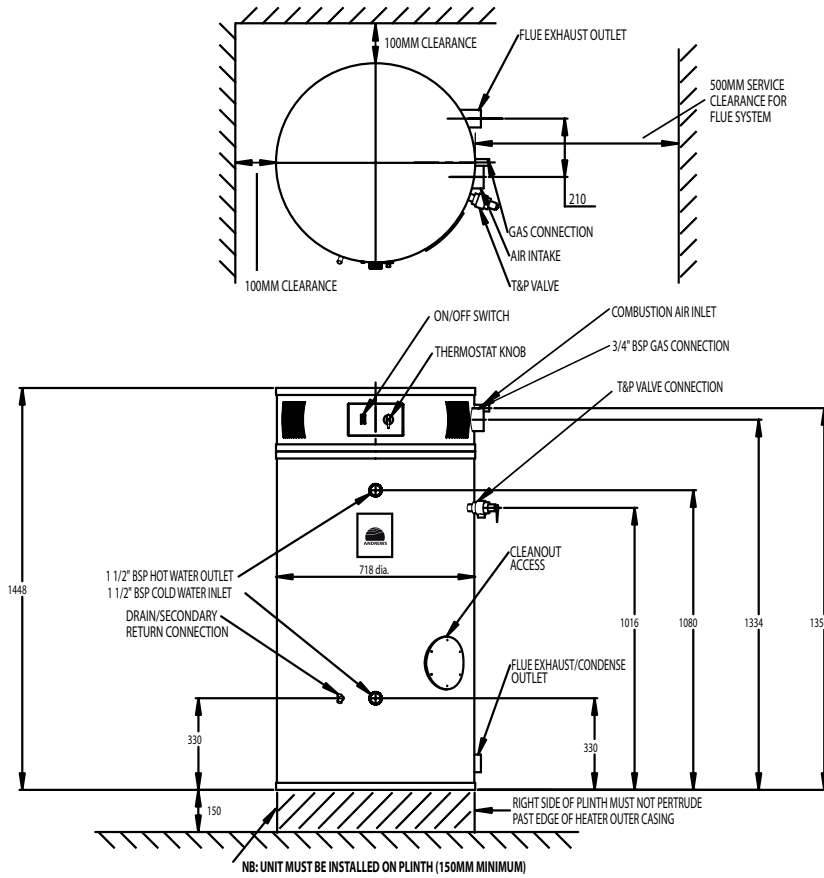

## ECoflo Models EC380/740, EC380/980, EC380/1220, EC380/1400

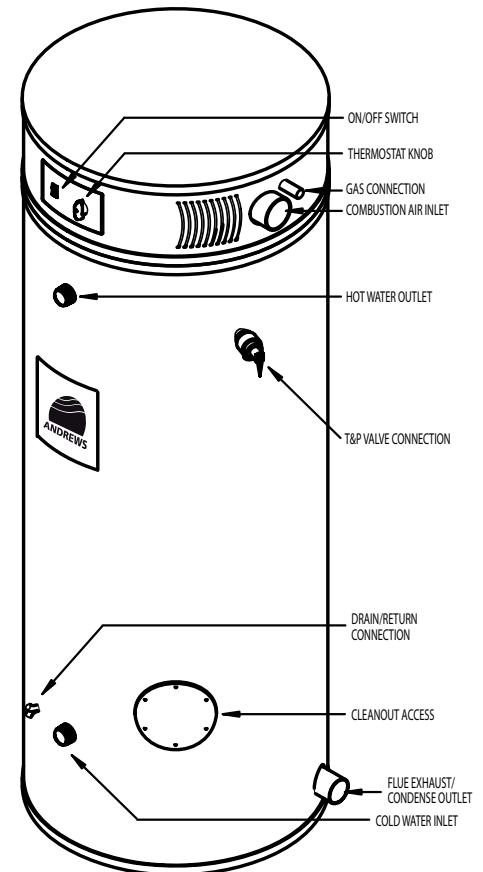
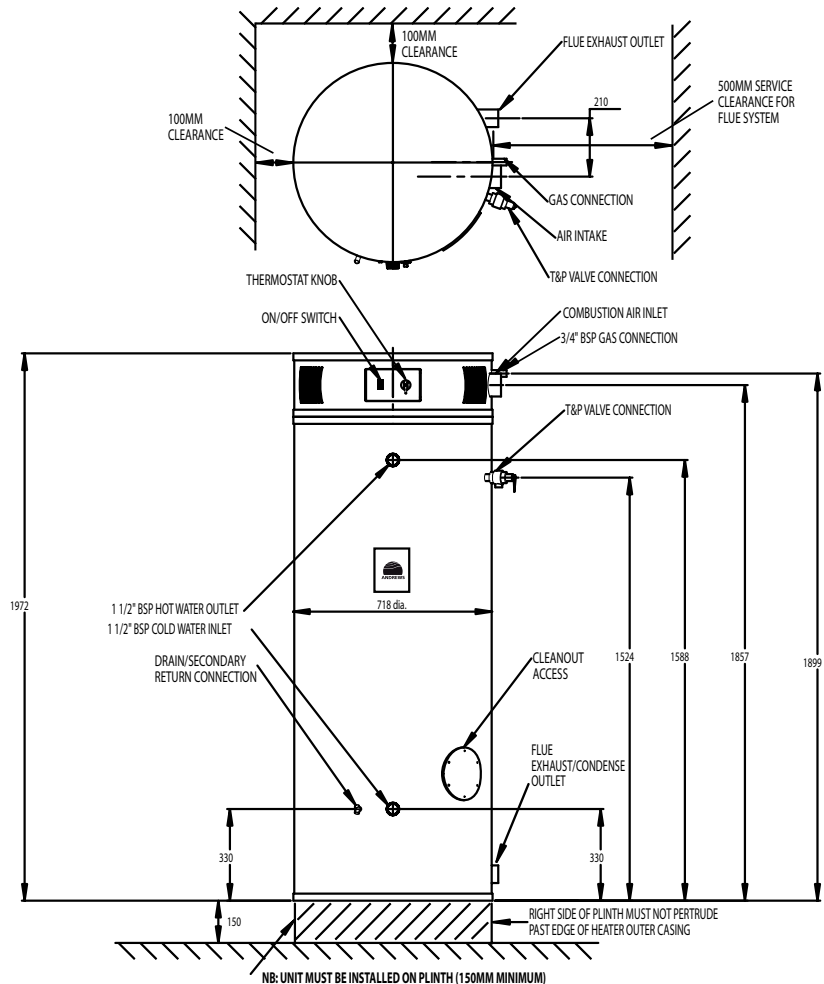

## Standard features

The EC  $\phi$ lo Condensing Storage Water Heater range incorporates a Three Pass Flue System, Low NO<sub>x</sub> Pre-Mix Power Burner and Submerged Combustion Chamber located in the centre of the water storage tank minimizing radiant heat loss and improving efficiency levels. The concentric flue system allows horizontal or vertical termination with maximum flue runs of up to 16 metres. The complete EC  $\phi$ lo range has Correx Powered Anodes fitted, this standard feature reduces associated service costs as the anode is maintenance free. The factory installed Hydrojet reduction system on the cold inlet connection helps to prevent sediment build up at the base of the tank.

## Ancillary equipment

The following ancillary items are available for the EC  $\phi$ lo range.

- Unvented System Kit 28mm dia. for direct connection to the mains water supply or booster pump system.
- Direct Storage Tanks, Vitraglas lined, available in three sizes: 300, 455 and 755 litres.
- A comprehensive range of concentric flue components are available.

See our price list or contact our sales team for further details on the above.

## Heater installation, system & sizing

The installation guide, operation and maintenance manual supplied with each appliance provides full installation details. This manual is also available as a hard copy, can be sent electronically and is included on our website: [www.andrewswaterheaters.co.uk](http://www.andrewswaterheaters.co.uk)

## Horizontal/Vertical Flue Kits

The EC  $\phi$ lo Range Horizontal or Vertical Concentric Flue Kits must be ordered separately with each water heater as detailed below:

B291 - Horizontal Flue Kit, EC230 models (100/150mm dia.), comprising horizontal flue terminal c/w wall plates and clamp (E236), 90° exhaust outlet tee c/w condense connection (E860), 100mm to concentric exhaust connector (E861), air intake tee piece connector syphon (E863) and fittings pack. elbow (E205), (E862), condense

B292 - Horizontal Flue Kit, EC380 models (100/150mm dia.), comprising horizontal flue terminal c/w wall plates and clamp (E236), 90° exhaust outlet tee c/w condense connection (E860), 100mm to concentric exhaust connector (E865), air intake tee piece connector syphon (E863) and fittings pack. elbow (E205), (E862), condense

B293 - Vertical Flue Kit, EC230 models (100/150mm dia.), comprising vertical flue terminal c/w clamp (E866), exhaust outlet tee c/w c connection (E860), 100mm to concentric exhaust connector (E861), air intake tee piece connector (E862), condense syphon (E863) and fittings pack. condense and fittings pack.

B294 - Vertical Flue Kit, EC380 models (100/150mm dia.), comprising vertical flue terminal c/w clamp (E866), exhaust outlet tee c/w c connection (E860), 100mm to concentric exhaust connector (E865), air intake tee piece connector (E862), condense syphon (E863) and fittings pack. condense and fittings pack.

## Flue terminal positions

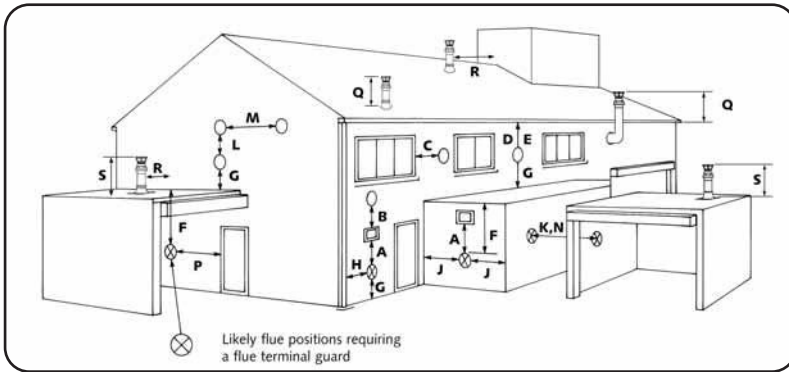

Horizontal/Vertical Terminal Position with Minimum Distance

mm		mm		mm		mm					
A	Directly below an opening, air brick, opening window etc.	300	E	Below the eaves	200	J	From an internal or external corner	300	N	From a terminal facing the terminal	1200
B	Above an opening, air brick opening window etc.	300	F	Below a balcony or carport roof	200	K	From a surface or boundary facing the terminal	600	P	From an opening in a carport (e.g. door, windows) into the building	1200
C	Horizontally to an opening, air brick, opening window etc.	300	G	Above ground, roof or balcony level	300	L	Vertically from a terminal on the same wall	1500	Q	Above roof	500
D	Below a gutter or sanitary pipework	75	H	From vertical drain/soil pipework	150	M	Horizontally from a terminal on the same wall (up to 70kw)	300	R	From a vertical structure on a roof	500
							(over 70kw)	600	S	Above flat roof	1000



Andrew Water Heaters  
 Wood Lane, Erdington,  
 Birmingham, B24 9QP  
 Tel: 0845 070 1055 Fax: 0845 070 1059  
 Email: [andrews@baxigroup.com](mailto:andrews@baxigroup.com)  
[www.andrewswaterheaters.co.uk](http://www.andrewswaterheaters.co.uk)