

# *User's Instructions*

## **Alpha CD12S/20S/28S**

**Wall Mounted, Fan Assisted, Room Sealed, Gas Fired,  
High Efficiency Condensing System Boiler**

For Technical help or for Service call ...  
**ALPHA HELPLINE Tel: 0870 3001964**  
website:www.alpha-innovation.co.uk

**Alpha**  
HEATING INNOVATION

Nepicar House, London Road,  
Wrotham Heath, Sevenoaks,  
Kent TN15 7RS

**British Gas**  
Service Listed



Alpha CD12S	G.C. No. 41 532 16
Alpha CD20S	G.C. No. 41 532 18
Alpha CD28S	G.C. No. 41 532 20



**For use with Natural Gas only**  
**Leave these instructions with the User**

## 1 DESCRIPTION

The Alpha CD12S, 20S and 28S are high efficiency condensing wall mounted, fan assisted room-sealed system boilers. The boilers are system boilers providing heating only for sealed central heating systems.

The CD12S boiler is suitable for central heating loads of between 2.4 and 12.8 kW (8 200 and 43 650 Btu/h).

The CD20S boiler is suitable for central heating loads of between 3.3 and 19.5 kW (11 260 and 66 500 Btu/h).

The CD28S boiler is suitable for central heating loads of between 5.4 and 30.1 kW (18420 and 102 700 Btu/h).

The boilers will provide central heating (as required) during the 'on' times set on your clock (if fitted).

The burner is lit electronically.

## 2 USER CONTROLS

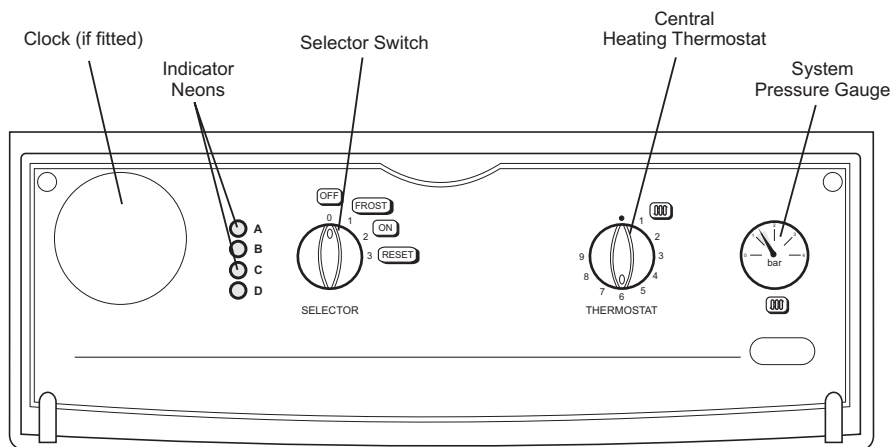

Fig. 1

## 3 BOILER CONTROLS

### 1. CENTRAL HEATING THERMOSTAT

This thermostat controls the temperature of the water leaving the boiler for the heating system. For maximum efficiency from the boiler the thermostat should be left at number 5 or 6 as shown in Fig. 1. If lower heating temperatures are required, turn the thermostat anti-clockwise. If higher temperatures are required, turn the thermostat clockwise.

### 2. SELECTOR SWITCH

This control is used to turn the boiler on and off or to 'reset' the ignition sequence or to set to frost thermostat only. The internal clock (if fitted) and frost thermostat will not operate when the switch is in the vertical position, i.e. 'Off' position (0).

### 3. PRESSURE GAUGE

This indicates the central heating system pressure. It should always be within the green band when cold, increasing slightly when hot.

If the pressure falls below the green band, i.e. lower red area, the system needs re-pressurising. Contact your Installer to have the system checked and pressurised.

#### 4. INDICATOR NEONS

When neons A (red), B (red), C (yellow), D (green) are illuminated, the following conditions apply:-

##### Neon

- D Illuminated continuously - Electricity supply to the boiler is on.
  - C Illuminated continuously - Burner is alight.
  - A Flashing on and off - Temperature sensor fault, contact your Service Engineer.
  - B Flashing on and off - Overheat thermostat has operated. Rotate selector switch to the reset position (3) to reset. If this continues to happen, contact your Service Engineer.
  - B Illuminated continuously - Burner has failed to light. Rotate selector switch to the reset position (3) and the ignition sequence will restart after a delay of about 30 seconds.
- A and B Flashing on and off at the same time - Blocked flue or fan fault, contact your Service Engineer.
- A and B Flashing on and off alternately - System pressure is very low and re-pressurisation is required.
- A Flashing and B Illuminated continuously - Pump fault or restricted flow.
- Note:** Do not hold the selector switch in the reset position (3) for more than 2 or 3 seconds.

#### 5. OVERHEAT THERMOSTAT

This thermostat automatically switches the boiler off in the unlikely event of the boiler overheating. When the thermostat operates, the red neon (B) flashes on and off. Rotate the selector switch to the reset position (3) and the boiler will relight. If this continually happens, contact your Service Engineer.

#### 6. PRESSURE RELIEF VALVE

If the central heating system overheats and steam or water is discharged from the pipe connected to this valve, turn the boiler off and contact your Service Engineer. Your Installer should have shown you where this pipe terminates, usually outside your dwelling.

#### 7. FROST THERMOSTAT

The boiler has a built-in frost thermostat, which automatically operates the boiler if the water temperature falls below 4°C, providing the electrical supply is on and the selector switch is set to position (1) or position (2).

## 4 LIGHTING INSTRUCTIONS

Refer to Fig. 1 for boiler controls.

1. Ensure the following:-
  - a. Electrical supply to the boiler is off.
  - b. All heating controls and thermostats are set to OFF or minimum position.
  - c. All isolation valves at the bottom of the boiler are in the open position (slot on the spindle in line with the valves i.e. ).
  - d. The gas and water supplies are on at the mains.
  - e. The heating system pressure is within the green band as shown by the pressure gauge.
2. Switch on the electrical supply to the boiler.
3. Set any room thermostats to maximum and ensure that any clock is in an 'on' position.
4. Set the selector switch to position (2) and turn the heating thermostat fully clockwise. The main burner will light and the boiler will provide central heating.
5. Set the boiler thermostats, clock, external controls i.e. room thermostat to your chosen settings and the boiler is ready to operate.

**To turn the central heating off i.e. in Summer:-** Set the selector switch to position (1).

**To turn the boiler off for short periods:-** Set the selector switch to position (1).

**Note:** In this position the pump will automatically operate for 30 seconds in every 24 hours. If the water temperature falls below 4°C the built-in frost thermostat will operate the boiler automatically until the temperature of the water in the heating system has been raised.

**To turn the boiler off for longer periods:-** Switch off the electrical supply to the boiler. If required, all supplies i.e. gas, water and electricity may be turned off at the mains. If there is any possibility of the boiler being left during frost conditions, then the boiler and system should be drained and a label attached to the boiler drawing attention that the system has been drained. If this is required, contact your Service Engineer.

## 5 BOILER OPERATION

The operating sequence of the boiler is controlled by the selector switch on the control panel.

Setting the selector switch to position (2) the boiler will operate to provide central heating.

When the selector is set to central heating, it will respond to a demand for heat in the following sequence:-

- a. The pump will start, the fan will operate and the main burner will light.
- b. The output of the burner is automatically controlled to suit the system demand.
- c. When the temperature of the system water in the boiler reaches that set by the thermostat or the room thermostat is satisfied, the main burner is turned off and the fan stops after 50 seconds. The pump will continue to run for 3 minutes.

## 6 IMPORTANT NOTES

### 1. BOILER LOCATION

Always ensure the following clearances are available around the casing of the boiler (not including the bottom tray):-

Top: 235 mm, Bottom: 250 mm, Each side: 5 mm, Front: 450 mm

Do not store any other articles in the cupboard containing the boiler and never place any clothing or combustible material on or near the boiler or flue pipe.

### 2. FLUE TERMINAL

The terminal on the outside wall must not be allowed to be obstructed. If it is damaged, in any way, turn the boiler off and contact your Service Engineer.

**Note:** The Alpha CD boilers are high efficiency condensing boilers and when operating vapour will be emitted from the terminal. This is safe and quite normal.

### 3. MAINS FAILURE

In the event of an electrical supply failure the boiler will not operate. When the supply is restored, the boiler will return to normal operation. Remember to reset the clock, if fitted, when the supply is restored.

### 4. CLEANING

Use only a damp cloth and mild detergent to clean the boiler outer casing. Do not use abrasive cleaners.

### 5. SERVICING

To maintain efficient and safe operation of your boiler, routine annual servicing is essential.

For advice on servicing contact:- The Alpha Helpline: 0870 3001964.

### 6. GAS LEAK

If a fault or gas leak is suspected, turn off the gas supply. Do not touch any electrical switches, do not smoke and extinguish all naked flames. Contact your local Gas Region immediately.

### 7. ELECTRICAL SUPPLY

The boiler requires a 230/240 V ~ 50 Hz supply, fused at 3 A if a 13 A 3-pin plug is used or a 5 A fuse if any other type of plug is used.

#### To connect a plug:-

The colour of the wires in the mains lead of the boiler may not correspond with the coloured markings identifying the terminals in your plug. In this case proceed as follows:-

The wire coloured green and yellow must be connected to the terminal in the plug that is marked with the letter **E**, or by the earth symbol , or coloured green or green and yellow.

The blue wire must be connected to the terminal which is marked with either the letter **N** or coloured black.

The brown wire must be connected to the terminal which is marked with the letter **L** or coloured red.

**THE APPLIANCE MUST BE EARTHED.**

## 7 GAS SAFETY REGULATIONS

Current Gas Safety (Installation and Use) Regulations:-

It is the law that all gas appliances are installed and serviced by a competent person, i.e. CORGI registered personnel. Failure to install or service appliances correctly could lead to prosecution. It is in your interest and that of safety to ensure compliance with the law. The manufacturer's instructions must not be taken in any way as over-riding statutory obligations.

The Benchmark Checklist must be fully completed by the installer on installation and commissioning of the boiler. The Benchmark Checklist is shown in Section 12 of the Installation and Servicing instructions. All CORGI registered installers carry a CORGI ID card and have a registration number. Both should be recorded in the Checklist. You can check your installer is CORGI registered by calling CORGI on 01256 372300.

## 8 FAULT FINDING FOR THE USER

If you experience a problem of no heating and, if applicable, no hot water, try to solve the problem by following the simple checks below before calling out a service engineer.

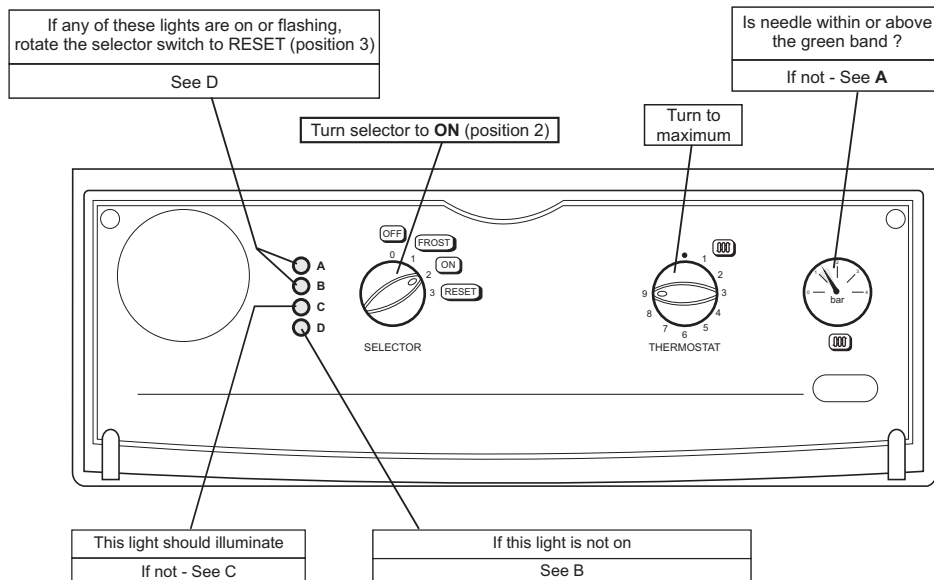

**A** - The system needs re-pressurising.

To have the system checked and re-pressurised contact your installer. Or

**B** - Check that the electrical supply to the boiler is on. If so

**C** - Check that all controls are calling for heat, i.e. room thermostat, clock. If so

**D** - Check that the gas supply is on. If the light continues to come on after resetting

**E** - Contact the Alpha Helpline

**Ring the  
Alpha Helpline Service  
Tel: 0870 3001964**

You will be asked  
the Serial No. of your  
boiler when you ring.

The Serial No. of the  
boiler is on the inside  
of the hinged cover.





**Alpha**  
HEATING INNOVATION

Alpha Therm Limited.  
Nepicar House, London Road, Wrotham Heath,  
Sevenoaks, Kent TN15 7RS  
Tel: 0870 3001964

email: [info@alphatherm.co.uk](mailto:info@alphatherm.co.uk)  
website: [www.alpha-innovation.co.uk](http://www.alpha-innovation.co.uk)

*These instructions have been carefully prepared but we reserve the right to alter the specification at any time in the interest of product improvement.  
© Alpha Therm Limited 2008.*

**Part No. 1.024837**