

showermate

Standard Twin Pumps

Showermate pumps are designed to boost the performance of shower and tap outlets within a bathroom.

Suitable for domestic use only, Showermate Standard pumps will function under positive head conditions and are suitable for installation into open vented hot and cold water systems.

Standard pumps require a flow of just 0.8 l/min to start.



Features

- Durable plastic construction
- 1.8 and 2.6 bar performance options
- Automatic switching
- Nitrile/carbon/ceramic seal
- Continuously rated
- 15 mm push-in flexible hoses with integral isolating valves on inlets
- G 3/4 threaded connections
- Pre-wired with 1.5 metre power cable
- Anti-vibration feet
- 3-year guarantee (subject to conditions)

Application

- Boost hot and cold water supplies equally
- Suitable for single or multiple (up to 4) outlets subject to correct specification and pump sizing

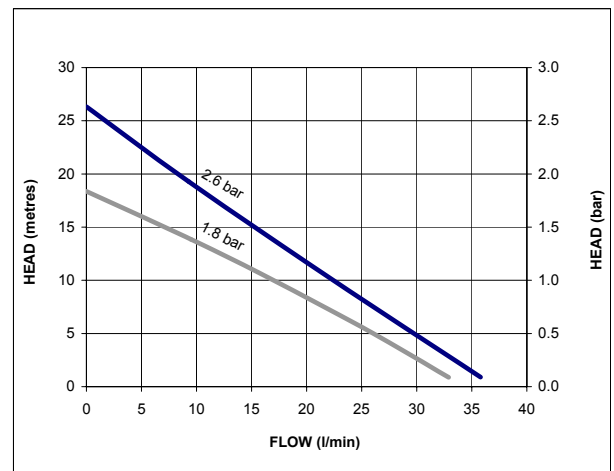

For further advice on selecting the correct pump call or e-mail info@stpumps.co.uk

pumpassist
HELPLINE +44 (0) 844 98 000 97

showermate

Pump Model		S1.8 bar Twin 46407	S2.6 bar Twin 46431
General	Guarantee	3 years	
	WRAS approval	1207070	
Features	Pump type	Peripheral	
	Mechanical seal	Nitrile / Carbon / Ceramic	
	Anti-vibration feet	✓	✓
	Flexible hoses	4	4
	Dry run protection	✓	✓
Performance	Maximum head (closed valve)	1.8 bar	2.6 bar
	Performance @ 9 l/min	1.5 bar	1.9 bar
	Performance @ 18 l/min	0.8 bar	1.3 bar
	Maximum flow	33 l/min	36 l/min
	Maximum static inlet pressure	13 metres	
	Maximum working pressure*	380 kPa (3.8 bar)	
	Maximum ambient air temperature	40 °C	
	Min / Max water temperature**	Min 4 °C / Max 65 °C	
Flow switch sensitivity (approx)	0.8 l/min		
Connections	Pump connections	G ¾ male	
Flexible hoses	Connections	G ¾ female x 15 mm push-in x 200 mm long, isolating valves on inlet hoses	
Motor	Type	Induction, auto-reset thermal trip	
	Duty rating	Continuous (S1) @ 9 l/min and above***	
Electrical	Power supply / phase / frequency	230 V a.c. / 1 / 50 Hz	
	Current (full load)	1.8 Amps	2.2 Amps
	Power consumption	405 Watts	505 Watts
	Fuse rating	5 Amps	
	Power cable (pre-wired)	1.5 metres	
Physical	Enclosure protection	IP22	
	Length	304 mm	319 mm
	Width	132 mm	
	Height (excluding hoses)	179 mm	
	Weight (including fittings)	4.7 Kg	5.5 Kg

* The maximum pressure that can be applied to the pump under any installation conditions.

** A stored water temperature of 60 °C is considered sufficient to meet all normal requirements and will minimise deposition of scale in hard water areas.

*** Both heads pumping 4.5 l/min and above.

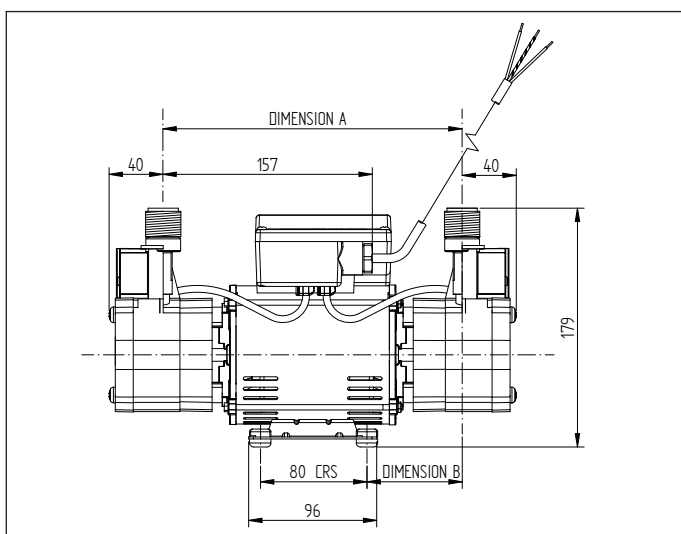

Pump Description	Dim. 'A'	Dim. 'B'
S1.8 bar Twin	224 mm	71 mm
S2.6 bar Twin	239 mm	79 mm

Stuart Turner Limited reserves the right to amend specifications without notice.